

Professional 15" woofer designed to meet a variety of PA needs for small and medium-sized rooms, with excellent performance in the mid and low frequency ranges.

For sound reinforcement in nightclubs, dancing halls, auditoriums, bands and also for studio monitors.

Its great efficiency in sound reproduction is due to the excellent combination of the different components:

- The light cone manufactured with long fiber pulp together with a surround of impregnated fabric give the array great stability, high yield and low distortion.

- The voice coil is made of high temperature wire, wound on Kapton® former.

- The epoxy painted reinforced steel frame provides the array with high mechanical resistance.

- The aluminum dust cap guarantees great voice coil heat dissipation.

- The use of highly resistant adhesives guarantees optimal cohesion and durability of components.

\*15PW3-SLF: Product with black dull finished dust cap and without Selenium logo printed on it.



### SPECIFICATIONS

Nominal diameter	380 (15)	mm (in)
Nominal impedance	8	Ω
Minimum impedance @ 160 Hz	6.8	Ω
Power handling		
Musical Program <sup>1</sup>	500	W
AES <sup>2</sup>	250	W
Sensitivity (2.83V@1m) averaged from 100 to 2,000 Hz	98	dB SPL
Power compression @ 0 dB (nom. power)	4.1	dB
Power compression @ -3 dB (nom. power)/2	2.5	dB
Power compression @ -10 dB (nom. power)/10	0.6	dB
Frequency response @ -10 dB	40 to 4,000	Hz

<sup>1</sup> Power handling specifications refer to normal speech and/or music program material, reproduced by an amplifier producing no more than 5% distortion. Power is calculated as true RMS voltage squared divided by the nominal impedance of the loudspeaker.

<sup>2</sup> AES Standard (60 - 600 Hz).

### THIELE-SMALL PARAMETERS

Fs	37	Hz
Vas	274 (9.67)	l (ft <sup>3</sup> )
Qts	0.61	
Qes	0.68	
Qms	5.81	
η <sub>0</sub> (half space)	2.00	%
Sd	0.08605 (133.4)	m <sup>2</sup> (in <sup>2</sup> )
Vd (Sd x Xmax)	258.2 (15.76)	cm <sup>3</sup> (in <sup>3</sup> )
Xmax (max. excursion (peak) with 10% distortion)	3.0 (0.12)	mm (in)
Xlim (max. excursion (peak) before physical damage)	9.5 (0.37)	mm (in)

Atmospheric conditions at TS parameter measurements:

Temperature	27 (81)	°C (°F)
Atmospheric pressure	1,000	mb
Humidity	43	%

Thiele-Small parameters are measured after a 2-hour power test using half AES power. A variation of ± 15% is allowed.

### ADDITIONAL PARAMETERS

βL	12.3	Tm
Flux density	1.15	T
Voice coil diameter	60 (2.4)	mm (in)
Voice coil winding length	17.5 (57.4)	m (ft)
Wire temperature coefficient of resistance (α <sub>25</sub> )	0.00368	1/°C
Maximum voice coil operating temperature	215 (419)	°C (°F)
θ <sub>vc</sub> (max. voice coil operating temp./max. power)	0.86 (1.68)	°C/W (°F/W)
H <sub>vc</sub> (voice coil winding depth)	14.0 (0.55)	mm (in)
H <sub>ag</sub> (air gap height)	8.0 (0.32)	mm (in)
Re	6.3	Ω
Mms	71.2 (0.157)	g (lb)
Cms	265.3	μm/N
Rms	2.8	kg/s

### NON-LINEAR PARAMETERS

Le @ Fs (voice coil inductance @ Fs)	2.475	mH
Le @ 1 kHz (voice coil inductance @ 1kHz)	0.929	mH
Le @ 20 kHz (voice coil inductance @ 20 kHz)	0.384	mH
Red @ Fs	0.11	Ω
Red @ 1 kHz	2.31	Ω
Red @ 20 kHz	36.56	Ω
K <sub>rm</sub>	0.728	mΩ
K <sub>xm</sub>	12.311	mH
E <sub>rm</sub>	0.922	
E <sub>xm</sub>	0.705	

### ADDITIONAL INFORMATION

Magnet material	Barium ferrite
Magnet weight	1,600 (57) g (oz)
Magnet diameter x depth	169 x 19 (6.65 x 0.75) mm (in)
Magnetic assembly weight	4,360 (9.61) g (lb)
Frame material	Steel
Frame finish	Black epoxy
Magnetic assembly steel finish	Zinc-plated
Voice coil material	Copper
Voice coil former material	Polyimide (Kapton®)
Cone material	Long fiber pulp
Volume displaced by woofer	4.0 (0.141) l (ft <sup>3</sup> )
Net weight	5,390 (11.88) g (lb)
Gross weight	6,100 (13.45) g (lb)
Carton dimensions (W x D x H)	39 x 39 x 16.5 (15.4 x 15.4 x 6.5) cm (in)

### MOUNTING INFORMATION

Number of bolt-holes	8
Bolt-hole diameter	5.5 (0.22) mm (in)
Bolt-circle diameter	367 (14.45) mm (in)
Baffle cutout diameter (front mount)	352 (13.86) mm (in)
Baffle cutout diameter (rear mount)	348 (13.70) mm (in)
Connectors	Push on terminals
Polarity	Positive voltage applied to the positive (+) terminal gives forward cone motion
Minimum clearance between the back of the magnetic assembly and the enclosure wall	75 (3) mm (in)

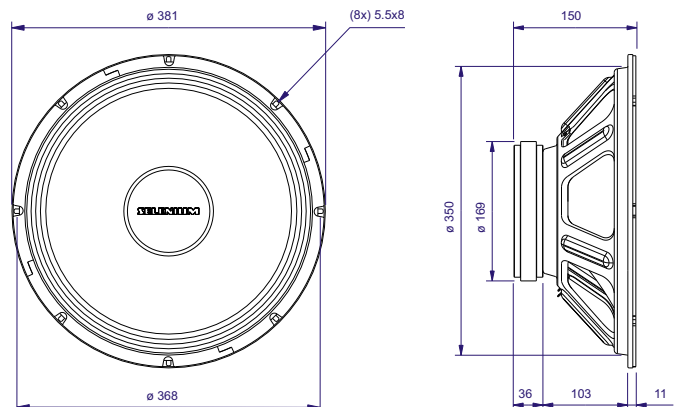

Dimensions in mm.

### RESPONSE CURVES (0° AND 45°) IN A TEST ENCLOSURE INSIDE AN ANECHOIC CHAMBER, 1 W / 1 m

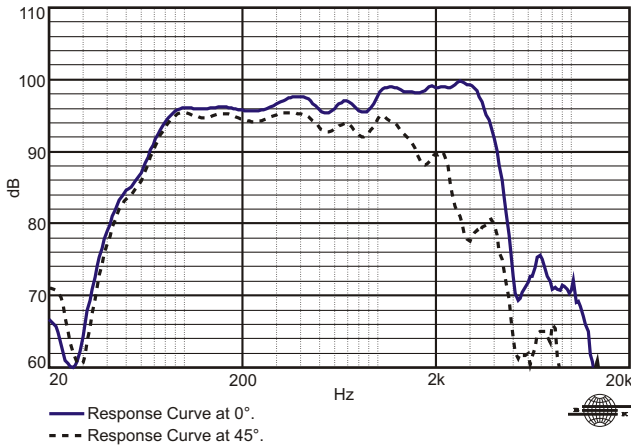

### IMPEDANCE AND PHASE CURVES MEASURED IN FREE-AIR

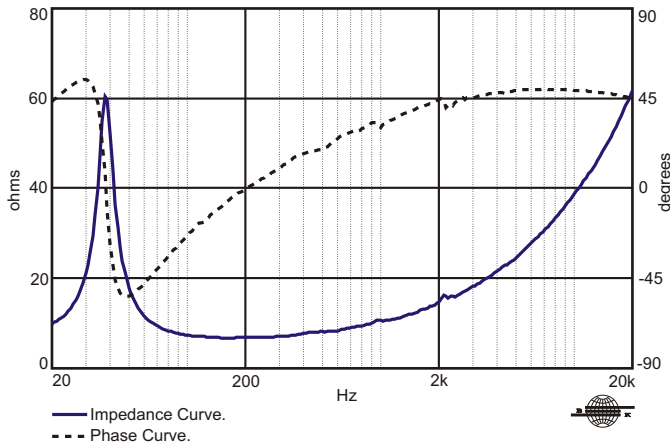

### HARMONIC DISTORTION CURVES MEASURED AT 10% AES INPUT POWER, 1 m

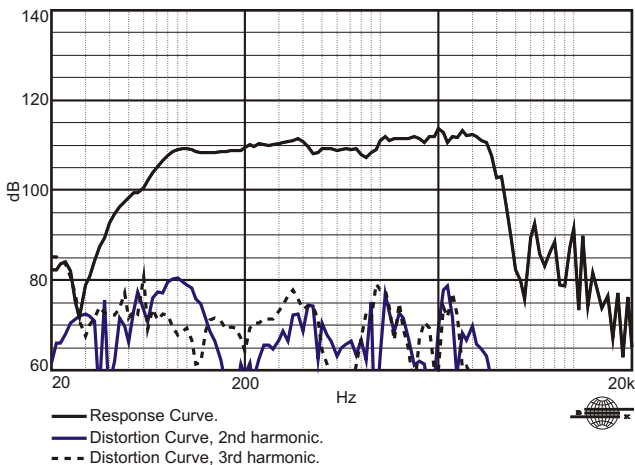

### POLAR RESPONSE CURVES

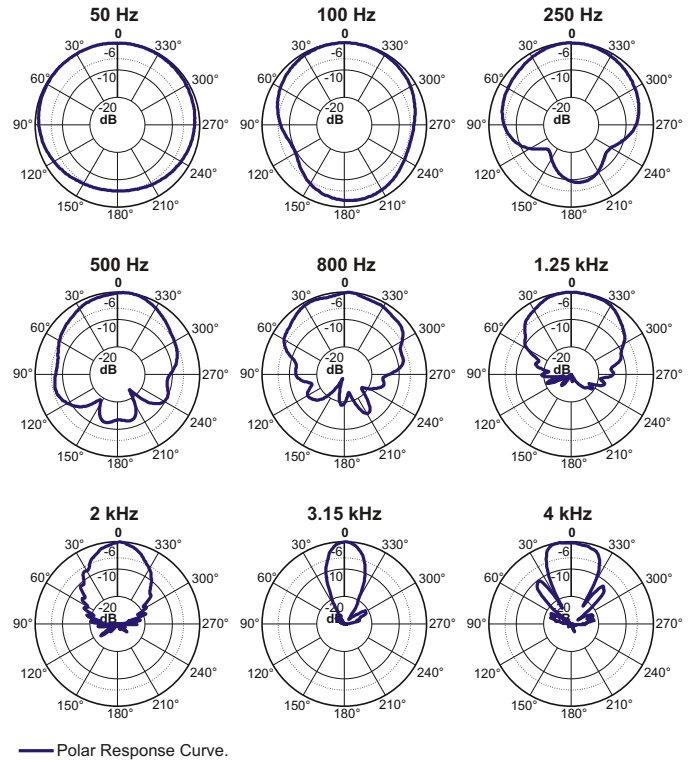

### HOW TO CHOOSE THE RIGHT AMPLIFIER

The power amplifier must be able to supply twice the RMS driver power. This 3 dB headroom is necessary to handle the peaks that are common to musical programs. When the amplifier clips those peaks, high distortion arises and this may damage the transducer due to excessive heat. The use of compressors is a good practice to reduce music dynamics to safe levels.

### FINDING VOICE COIL TEMPERATURE

It is very important to avoid maximum voice coil temperature. Since moving coil resistance ( $R_e$ ) varies with temperature according to a well known law, we can calculate the temperature inside the voice coil by measuring the voice coil DC resistance:

$$T_B = T_A + \left( \frac{R_B}{R_A} - 1 \right) \left( T_A - 25 + \frac{1}{\alpha_{25}} \right)$$

$T_A, T_B$  = voice coil temperatures in °C.

$R_A, R_B$  = voice coil resistances at temperatures  $T_A$  and  $T_B$ , respectively.

$\alpha_{25}$  = voice coil wire temperature coefficient at 25 °C.

### POWER COMPRESSION

Voice coil resistance rises with temperature, which leads to efficiency reduction. Therefore, if after doubling the applied electric power to the driver we get a 2 dB rise in SPL instead of the expected 3 dB, we can say that power compression equals 1 dB. An efficient cooling system to dissipate voice coil heat is very important to reduce power compression.

### NON-LINEAR VOICE COIL PARAMETERS

Due to its close coupling with the magnetic assembly, the voice coil in electrodynamic loudspeakers is a very non-linear circuit. Using the non-linear modeling parameters  $K_{rm}, K_{xm}, E_{rm}, E_{xm}$  from an empirical model, we can calculate voice coil impedance with good accuracy.

### SUGGESTED PROJECTS

MB15PW-A3    MB15PW-B3    MB15PW-C3    RB15PW-A2  
VB15PW-A2    VB15PW-C2

For additional project suggestions, please access our web site.

### TEST ENCLOSURE

110-liter volume with a duct  $\varnothing$  4" by 1.6" length.

Kapton®: Du Pont trademark.